



Eickhoff experience has no substitute

Shearer Loader SL 1000

The world's most powerful shearer loader, the Eickhoff SL 1000, is specifically designed to enable peak performance at coal mines with the extraction of seams with a height of up to 8,6 m.

But also customers with seams as low as 3,0 m can profit from this machine due to its modular principle of design, since and by just changing some minor components the exceptional cutting power can be installed in the lower seams as well.

Furthermore the Eickhoff SL 1000 features maximum tunnel clearance underneath the machine body allowing even the biggest lumps to pass smoothly.

Early in 2007 the SL 1000 was introduced to the world market with its first installation at Shenhua Energy/China.

The long experiences gained with the SL 500 under Shenhua's hard cutting conditions were consequently implemented into the new design of the SL 1000 for cutting heights up to 8,6 m.

Thus further remarkable production rate increases were achieved with the Eickhoff SL 1000 in operation.

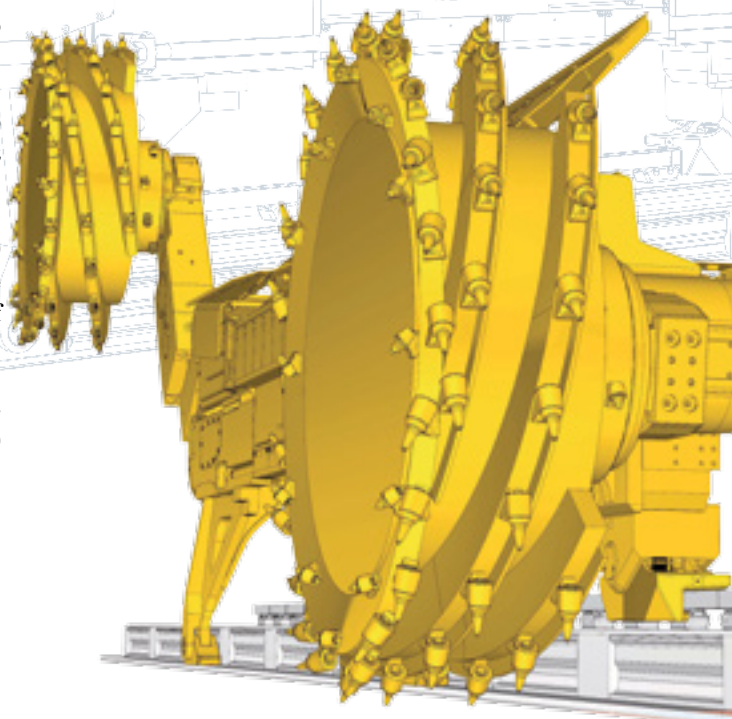

Technical Details

Operating Range	3,0 - 8,6 m
Voltage / Frequency	3300 V / 50 Hz
Total Installed Power	2800 kW
Cutting Drum Speed	29 - 41 rpm
Maxi. Haulage Speed	41 m/min
Total Weight	110 - 215 t